



CMC INDUSTRIES

Leading in Load Solutions



Agile

Designed for the poultry sector.



CMC INDUSTRIES. TWO DIVISIONS, ONE GREAT COMPANY

CMC Industries is an Italian company specialising in innovative conveyor solutions for the poultry and logistics industries. World leaders in the automatic loading of chickens and turkeys.

POULTRY DIVISION

- CHICKEN LOADERS
- TURKEY LOADERS
- FORKLIFTS
- ADDITIONAL EQUIPMENT

CMC transferred the skills and forty years of experience gained in machine design and construction of automatic belt transport systems, to the logistics sector: our second division.

LOGISTICS DIVISION

- EXPRESS COURIERS
- COMPLEX TRANSPORT SYSTEMS
- MOVING GOODS IN BULK, PARCELS AND PALLETS
- CUSTOMIZED SOLUTIONS

TO BE THE BEST THERE
IS ONLY ONE THING
TO DO: CONTINUE
TO IMPROVE.

We are a dynamic company, always looking for service improvements and machinery innovations that will benefit our customers.

We are flexible and adapt to the needs of our extremely diverse customer base.

We love technology: we continually design and develop innovative solutions.

We take care of our customers: we pride ourselves on providing exemplary customer service and support that goes above and beyond the sales transaction.



CMC Industries is a Company Member of EHEDG and follows the EHEDG guideline know-how.



HERE ARE THE STATS.

- 40** years of experience
- 85%** market share in the poultry division
- 57** patents registered since 1972
- 5%** of turnover invested in R&D

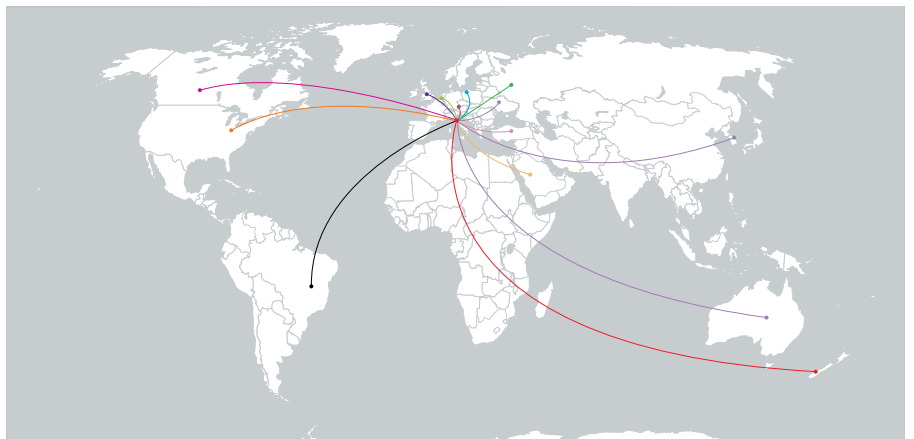

ENVIRONMENTALLY FRIENDLY – IT'S IN OUR DNA.

- Photovoltaic system capable of producing 610,000 Wh/year
- Reduce our CO₂ emission by 268 tons annually
- 100% energy independent
- Respect of directives and European standards



Photovoltaic roofing of the Company

AGILE: STRENGTHS

Agility

Quick and highly manoeuvrable, thanks to the short turning radius and reduced dimensions.

1

Comfort

Comfortable driver's seat.
Minimized in-cab vibrations.
Easy access to the driver's seat.
Simple joystick with forward/reverse command.

2

Created for the poultry industry

Triple air filter.
Protected blue headlamps.

3

Improved animal welfare

Smooth movements.
Forks with shock absorbers
for container stability
during transport.

4

Straightforward maintenance

Simple maintenance of the engine
and vital moving parts.
Completely hydraulic.
Essential electrical circuit.

5





10

Fast

Impressive acceleration with speeds of up to 21 km/h (13 mph).

9

Easy to clean

Specifically designed to facilitate easy, quick and effective daily cleaning with only water and disinfectant.

8

Less damage to containers and trucks

Precise maneuvering during container loading/unloading.

7

Safe

360° visibility.
Controlled and precise maneuverability.

6

Stability

Four wheel drive.
Low centre of gravity.
Centrally positioned engine.



**STRONG, FAST,
VERSATILE.
IN A WORD: AGILE.**

The Agile is a dexterous, powerful off-road forklift that has been specifically designed for the poultry sector. In the Agile, CMC Industries delivers superior maneuverability, increased operator safety and improved animal welfare. The engine size and power were designed to transport containers as efficiently as possible.

Sized specifically for poultry: the Agile was made to be used on poultry farms but, at only 1.65 meters tall and 3.30 meters long, it is also ideal for warehouses with low-ceilings or with several floors. The 3.3 meters turning radius lets you turn in the tight spaces and around columns, and the available powertrains provide all the power you need to move multiple containers. Along with performance, the Agile boasts fuel-efficiency and optimum torque for lifting and moving birds and containers. The Agile has a top speed of 21 km/h, which means containers can be transported rapidly from the truck to the shed and vice versa.

Maximum comfort: the Agile provides the operator with maximum comfort. The driver's seat and simple joystick controls make the work more intuitive than ever. The cab, which is usually open, can be enclosed (optional) and equipped with air conditioning. The driver's seat is easily accessible and vibrations have been drastically reduced thanks to the shock-absorbing seat suspension. All these features make the Agile extremely suitable for prolonged use, as is often the case when loading animals.





More safety and protection: because the Agile's **mast and forks are not aligned with the cab**, the operator has 360° visibility. This is a unique and significant advantage, especially when moving and loading cages, which requires absolute precision. The stability, visibility and driving precision cut the risk of damaging containers or other vehicles in use.

Animal welfare: the Agile guarantees superior animal protection thanks to its stability, the shock absorber on the forks and the limited incline of the mast. In fact, the birds in the container are subjected to far fewer bumps and less vibrations - even at high speed transport - compared to traditional industrial or telescopic forklifts.

Daily cleaning and disinfecting: cleaning and disinfecting equipment is a daily order of business on all poultry farms. For this reason, the Agile can be washed quickly and extremely easily every day. High pressure water and disinfectant are all that are needed to completely sanitise the machine. By design, the inside of the cab and the body can be washed without any risk of damaging the electric system or accessories. The Agile is also equipped with a triple air filter, making it suitable for operators who work in dirty and dusty conditions.



Cab-fork offset



All the answers for your questions.

HOW MUCH MAINTENANCE DOES THE AGILE NEED?

Thanks to the simplicity of the electric and hydraulic systems, maintenance requirements are drastically reduced as compared to industry-standard forklifts. The machine's motor and vital moving parts are easily accessible.

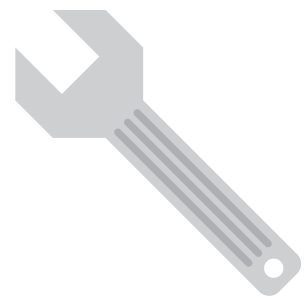

WHAT IF MY WAREHOUSE HAS SEVERAL FLOORS, A LOW CEILING OR PILLARS?

Agile is a short, compact machine and highly manoeuvrable. Its wide steering range makes it easy to move, even between obstacles or pillars.

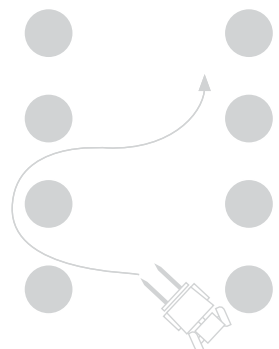



WHAT IF IT GETS VERY COLD OR VERY HOT?

The Agile has been designed to work in temperatures ranging from -40°C (-40°F) to $+50^{\circ}\text{C}$ (122°F).

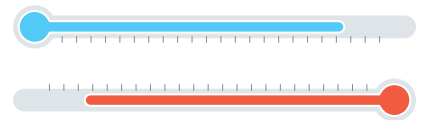

AND IN TERMS OF CLEANING?

Cleaning the Agile is extremely easy. Its body and main parts can be washed with water and disinfectant, significantly increasing biosecurity.

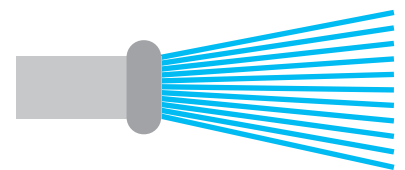

HOW MUCH FUEL DOES THE AGILE USE?

The Agile has been built to transport containers efficiently and quickly, with a powerful engine. But with a low weight to power ratio, the Agile uses significantly less fuel as compared to any other forklifts in the same class.

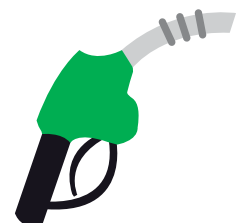

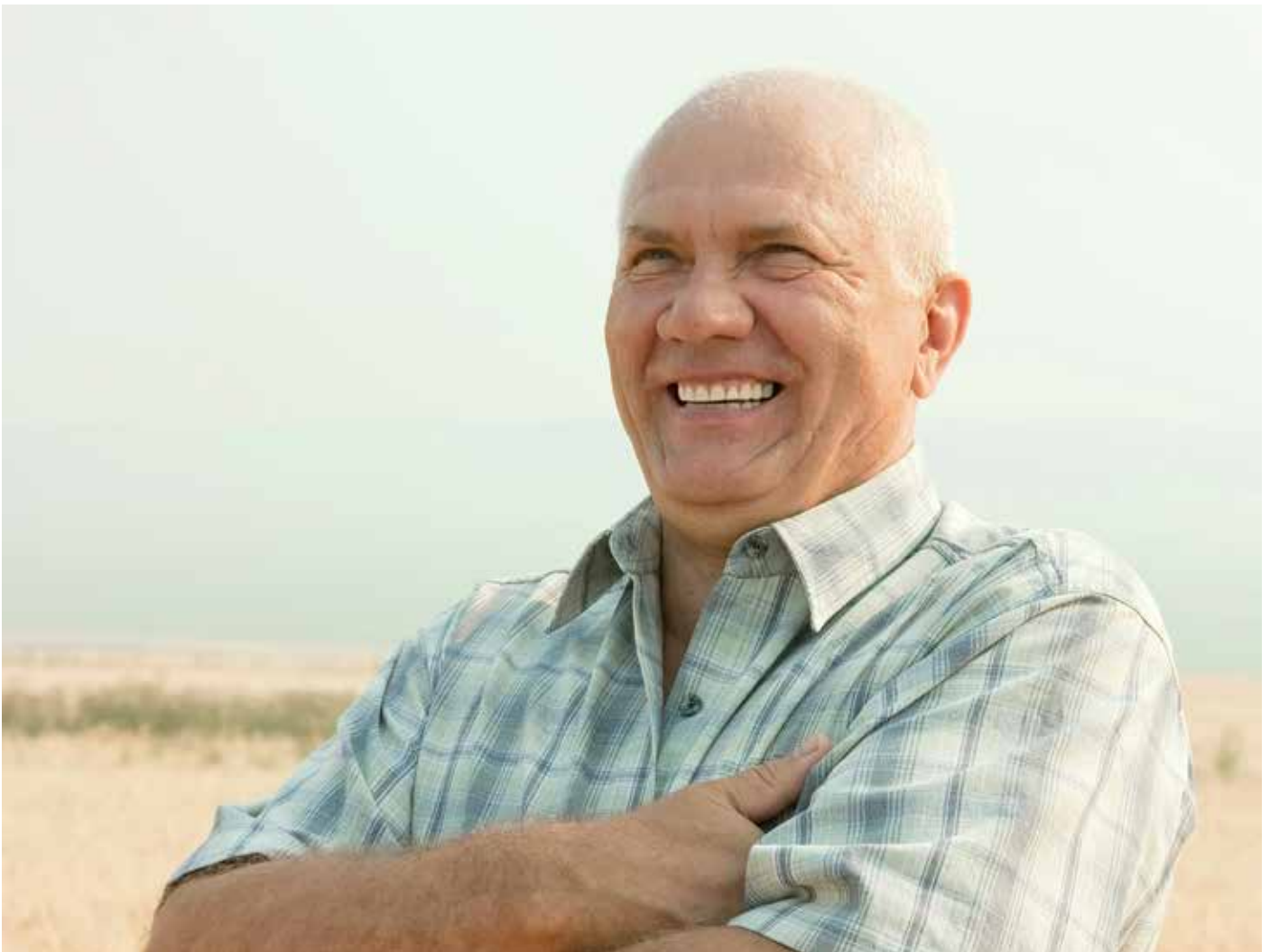

AFTER DELIVERY, YOU CAN STILL COUNT ON US.

We don't just sell equipment to our customers. We make sure they know how to maximize their returns by training them how best to use and maintain their CMC machinery.

Training: Either at our facility or on-site at the customer's location, we organise courses for the operators and technicians who will be using the CMC machines. We want to make sure that the people on the front lines are comfortable with the equipment, and understand its capabilities and best practices.

Assistance: In the event of an accident or breakdown, our customer service will be there to help. We are ready with technical support, spare parts and

the benefit of all our experience. We guarantee maximum efficiency and peace of mind, always.

Consulting: We are ready to face any kind of problem, together with our customers. We approach new challenges as an opportunity for further growth. Because of this, we offer advice, expertise and design solutions to meet even the most varied needs.

PERFORMANCE

Maximum capacity	2,000Kg (4,410 lb) @500mm from the plate
Maximum lifting height	3,050mm (low cab)/3,350mm (std cab)
Maximum machine height	1,650mm (low cab)/1,800mm (std cab)
Mast inclination angle	+10° / -10°
Breakout force	1,800 daN
Total weight unloaded	3,900Kg (8,598 lb) - 4,000Kg (8,818 lb)
Maximum speed	21 km/h (13 mph)

ENGINE

Model	Perkins 404 T or Kohler (Tier 4 Final)
Maximum power	47 kW-64 Hp (Perkins)/55 kW-75 Hp (Kohler)
Revolutions per minute	2,600 max
Functioning	4 stroke diesel
Cooling	liquid
Number of cylinders	4 vertical in line
Cylinder capacity	2,200 cc (Perkins)/2,500 cc (Kohler)
Consumption	13.3 l/h at full power

TRANSMISSION

Rexroth hydrostatic pump with variable cubic capacity
4 hydraulic Rexroth motors
Electrical joystick command
Electrohydraulic parking brake

HYDRAULIC SYSTEM

Hydrostatic pump with fixed cylinder capacity	65 l
Maximum pressure	160 bar

TYRES

Front/Back	10.0 / 75 - 15.3
------------	------------------

REFUELLING

Fuel tank	62 l
Hydraulic tank	120 l

STANDARD EQUIPMENT

Forks, sideshift, hydraulic socket, triple air filter, padded seat, fork shock absorber.

OPTIONAL EXTRAS AND ACCESSORIES

Cab lowering kit, cab closing kit, heating, air conditioning (heating included), fork shock absorber, rotator, 1,400 l bucket, ATF XT hydraulic oil for low temperatures, wide front tires.

ADDITIONAL INFORMATION

Cleaning	High pressure air and water
----------	-----------------------------

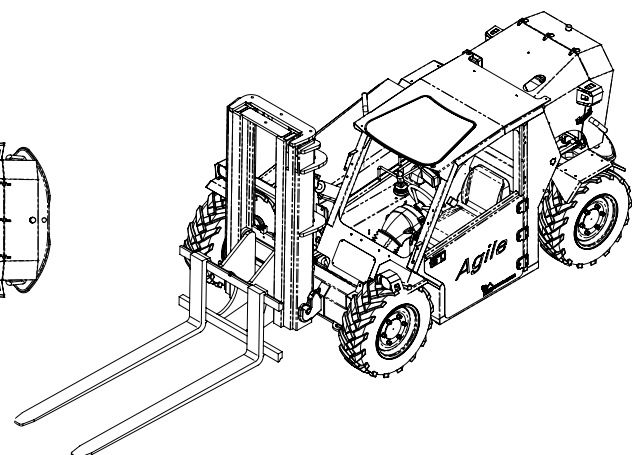
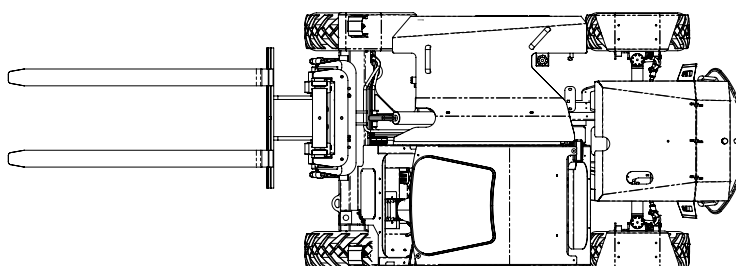
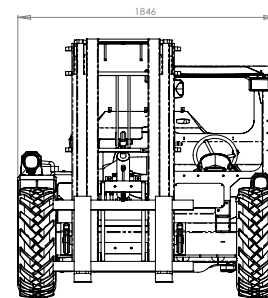
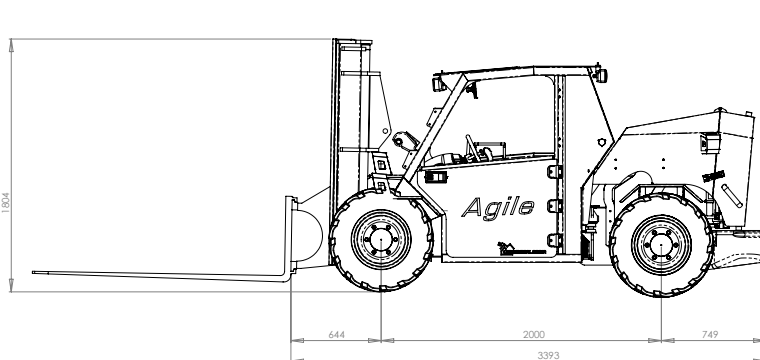



is the new name for

